

MICROLINEA SERIES 2 DIRECT WALL MOUNT SAFETY AND INSTALLATION INSTRUCTIONS

CAUTION:

- * BE CERTAIN THAT POWER TO FIELD WIRING HAS BEEN TURNED OFF PRIOR TO INSTALLATION.
- * CONNECTIONS TO FIELD WIRES AND GROUNDING OF FIXTURES MUST BE DONE IN ACCORDANCE WITH APPLICABLE LOCAL & NATIONAL CODES. INSTALLATION MUST BE PERFORMED BY QUALIFIED PERSONNEL.
- * IT IS INSTALLERS RESPONSIBILITY TO ENSURE THAT WALL, CEILING OR JUNCTION BOX IS STRUCTURALLY CAPABLE OF SUPPORTING WEIGHT OF FIXTURE.
- * BE CERTAIN THAT SUPPLY VOLTAGE IS THE SAME AS THAT MARKED ON DRIVERS AND TRANSFORMERS.

SINGLE FIXTURE INSTALLATION

STEP 1:

USING WALL CLEAT AS A TEMPLATE, CENTER OVER HORIZONTALLY MOUNTED SWITCH BOX AND MARK (2) MOUNTING HOLES. USE LEVEL TO PLUMB WALL CLEAT. (FIG 1) DRILL HOLES APPROPRIATE FOR MOUNTING SURFACE AND FASTENERS TO BE USED. SECURELY ATTACH CLEAT TO WALL.

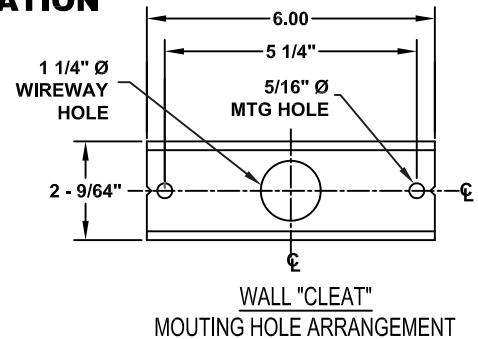

STEP 2:

ATTACH ADDITIONAL WALL CLEAT(S) TO MOUNTING SURFACE AT LOCATION(S) AS SPECIFIED ON FACTORY SHOP DRAWING. TAKE CARE TO ENSURE THAT WALL CLEATS ARE PLUMB AND ON SAME CENTER LINE AS FIRST ONE INSTALLED. WALL CLEATS SHOULD BE CENTERED OVER EVERY SET SCREW IN FIXTURE HOUSING AS INDICATED ON SHOP DRAWING. CONSULT FACTORY OR YOUR PAL REPRESENTATIVE IF YOU ARE NOT IN POSSESSION OF FACTORY SHOP DRAWING.

STEP 3:

CONNECT INCOMING SUPPLY WIRES TO FIXTURE WIRES USING 90°C MINIMUM RATED SUPPLY WIRES AND CONNECTORS. ALL WIRE CONNECTIONS SHOULD BE MADE INSIDE JUNCTION BOX.

STEP 4:

HOOK LIP OF FIXTURE HOUSING OVER TOP STEP OF WALL CLEATS AND HOLD FIXTURE AGAINST WALL. CHECK TO ENSURE THAT EXCESS WIRE LEADS ARE NOT PINCHED AND ARE WITHIN THE CONFINES OF THE SWITCH BOX. INSTALL SET SCREWS AND TIGHTEN ONLY ENOUGH TO HOLD FIXTURE SNUG AGAINST WALL. (FIG. 2)

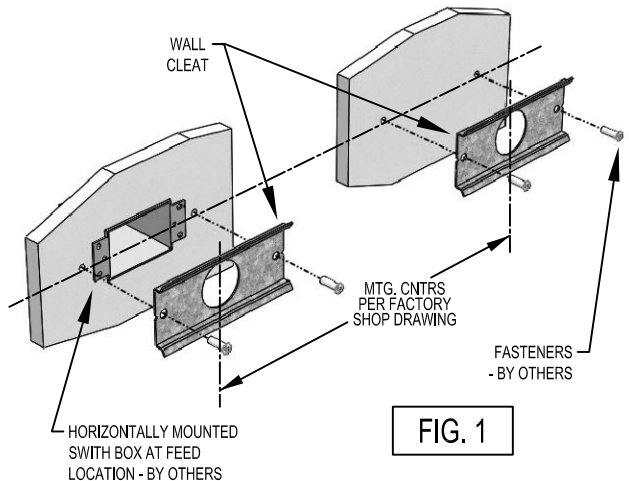

FIG. 1

STEP 5:

ENERGIZE CIRCUIT AND CHECK PROPER OPERATION.

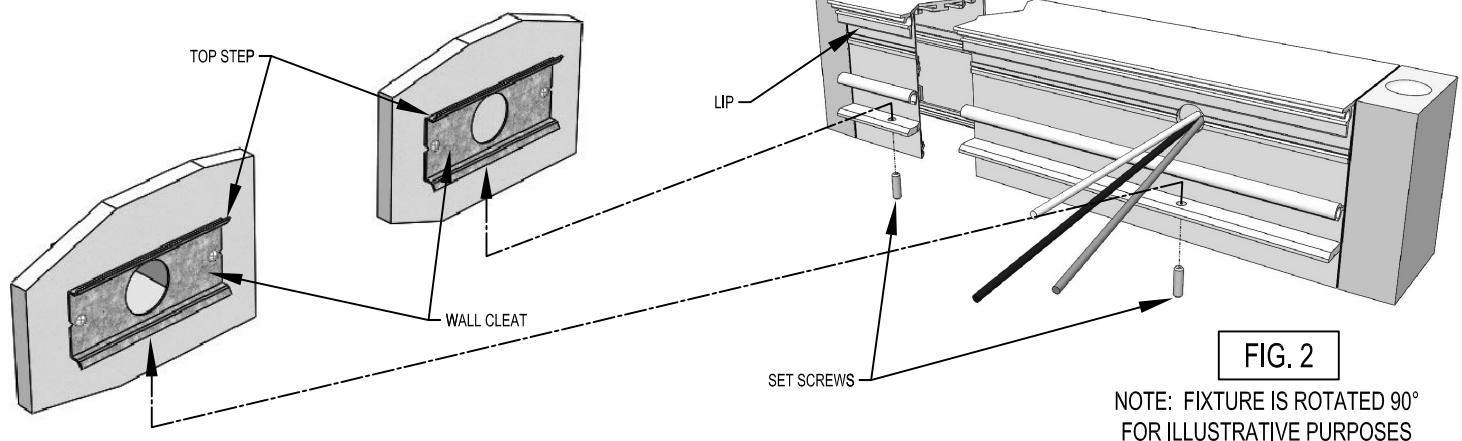

FIG. 2

REFERENCE BACK PAGE FOR CONTINUOUS ROW INSTALLATION



Precision Architectural Lighting

Tel (713) 946-4343 Fax (713) 946-4441 www.palighting.com

4830 Timber Creek Drive Houston, Texas 77017

PAL RESERVES THE RIGHT TO CHANGE PRODUCT DESIGN AND SPECIFICATIONS. CONTACT FACTORY FOR MOST RECENT PRODUCT INFORMATION.

3750162-1 9/14

MICROLINEA SERIES 2 DIRECT WALL MOUNT SAFETY AND INSTALLATION INSTRUCTIONS

ROW INSTALLATION

CAUTION

DO NOT ATTEMPT TO ASSEMBLE FIXTURE ROWS ON GROUND THEN LIFT INTO POSITION. ATTEMPTING TO ASSEMBLE & INSTALL FIXTURES IN THIS MANNER MAY CREATE STRESS AT CONNECTIONS RESULTING IN DAMAGE AND/OR MECHANICAL FAILURE.

STEP 1:

FROM CENTER LINE OF HORIZONTALLY MOUNTED SWITCH BOX(ES), SNAP A HORIZONTAL CHALK LINE ON WALL APPROXIMATELY FULL LENGTH OF FIXTURE ROW TO BE INSTALLED.

STEP 2:

ATTACH WALL CLEATS, AS INSTRUCTED ON OPPOSITE PAGE AND ON CENTERS AS SPECIFIED ON SHOP DRAWING, USING CHALK LINE AS CENTER LINE GUIDE. (FIG. 3)

NOTE: THE FOLLOWING STEPS MAY REQUIRE REMOVAL OF FIXTURE REFLECTOR TO COMPLETE INSTALLATION AND WIRING.

STEP 3:

INSTALL FIRST (END) FIXTURE IN ROW AS INSTRUCTED ON OPPOSITE PAGE. LEAVE SET SCREWS ON ALL FIXTURES LOOSE AT THIS TIME.

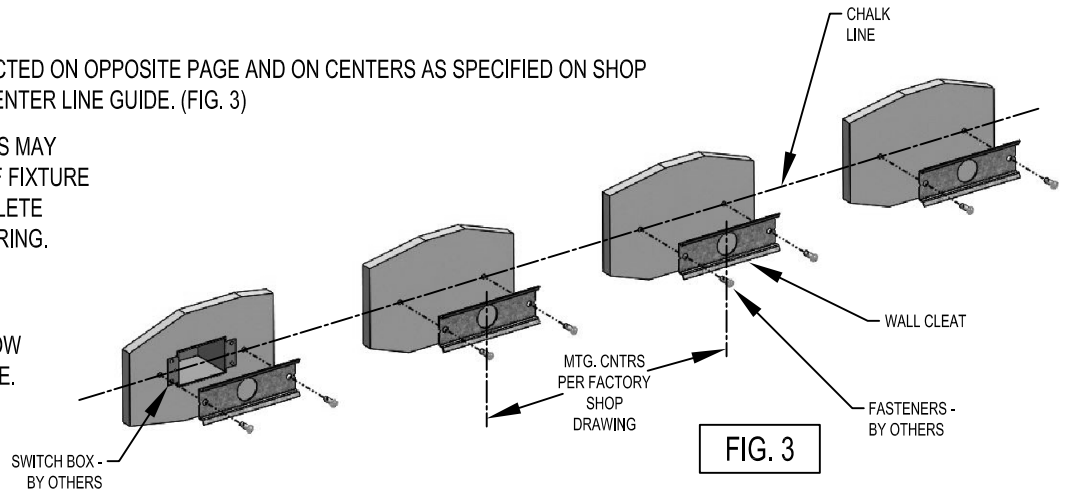

STEP 4:

POSITION SECOND FIXTURE SUCH THAT IT ALIGNS WITH THE JOINT END OF THE FIRST FIXTURE AS ILLUSTRATED. (FIG. 4)

STEP 5:

PLUG FIXTURE WIRE HARNESSSES TOGETHER AND PUSH EXCESS WIRE BACK INTO FIXTURE WIREWAY.

STEP 6:

PUSH FIXTURES TIGHTLY TOGETHER, MAKING SURE THAT ALIGNMENT SPLICES AND ALIGNMENT PLATE SLIDE INTO THE INTERIOR TRACKS OF THE FIRST FIXTURE. THE ALIGNMENT SPLICES SHOULD SPAN THE FIXTURE JOINT WHEN FIXTURES ARE PUSHED TOGETHER. SECURE FIXTURES TOGETHER WITH #10-24 NUTS & STUDS PROVIDED ON THE INTERIOR OF THE FIRST FIXTURE.

NOTE: MAKE SURE EXCESS WIRE FROM WIRE HARNESS IS PUSHED BACK INTO FIXTURE WIREWAY CHAMBER AND IS NOT 'PINCHED' BETWEEN FIXTURES.

STEP 7:

CONTINUE TO INSTALL & ASSEMBLE FIXTURE ROW FOLLOWING STEPS 4 THROUGH 6.

STEP 8:

ONCE ALL FIXTURES IN ROW ARE INSTALLED, TIGHTEN SET SCREWS ON ALL FIXTURES ONLY ENOUGH TO HOLD FIXTURE SNUG AGAINST WALL.

STEP 9:

ENERGIZE CIRCUIT AND CHECK FOR PROPER OPERATION.

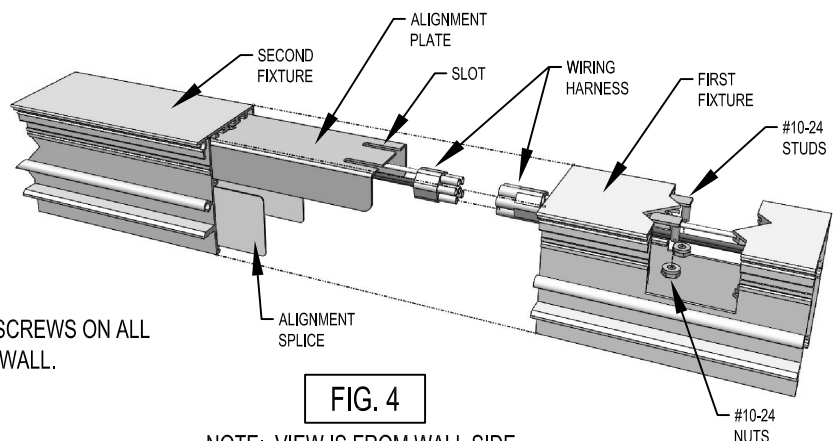

NOTE: VIEW IS FROM WALL SIDE FOR ILLUSTRATIVE PURPOSES

