

# AC19000 SERIES NON FEED CABLE ASSEMBLY SAFETY AND INSTALLATION INSTRUCTIONS

## CAUTION:

- \* BE CERTAIN THAT POWER TO FIELD WIRING HAS BEEN TURNED OFF PRIOR TO INSTALLATION.
- \* CONNECTIONS TO FIELD WIRES AND GROUNDING OF FIXTURES MUST BE DONE IN ACCORDANCE WITH APPLICABLE LOCAL & NATIONAL CODES. INSTALLATION MUST BE PERFORMED BY QUALIFIED PERSONNEL.
- \* IT IS INSTALLERS RESPONSIBILITY TO ENSURE THAT WALL, CEILING OR JUNCTION BOX IS STRUCTURALLY CAPABLE OF SUPPORTING WEIGHT OF FIXTURE .
- \* BE CERTAIN THAT SUPPLY VOLTAGE IS THE SAME AS THAT MARKED ON BALLASTS AND TRANSFORMERS.

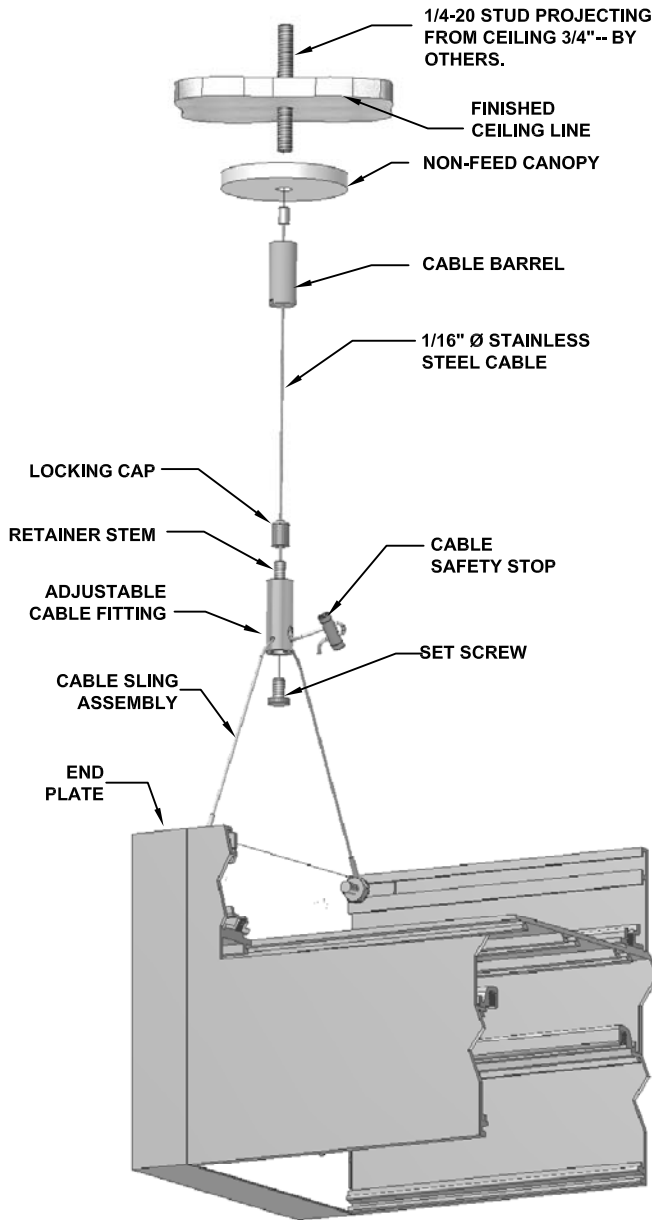

FIG. 1

### STEP 1:

DETERMINE MOUNTING CABLE SPACING (FROM FACTORY SHOP DRAWING) AND LOCATE 1/4-20 STUD (BY OTHERS) PROJECTING 3/4" FROM CEILING AT APPROPRIATE LOCATION(S).

### STEP 2:

HOLD CANOPY AGAINST CEILING SUCH THAT 1/4-20 STUD IS PASSING THROUGH CENTER HOLE AS ILLUSTRATED. THREAD CABLE BARREL WITH SWAGED CABLE INSERTED ONTO 1/4-20 STUD-TIGHTEN SECURELY.

### STEP 3:

SECURE CABLE SLING TO MOUNTING STUDS ON BOTH SIDES OF FIXTURE AS ILLUSTRATED (FIG. 1). TIGHTEN LOCKNUTS SECURELY ON BOTH SIDES.

**CAUTION:** DO NOT OVER-TIGHTEN LOCK NUT AS DAMAGE TO CABLE SLING ASSEMBLY MAY RESULT.

### STEP 4:

RAISE FIXTURE TO CABLE ASSEMBLY AND ROUTE CABLE THROUGH THE CENTER OF THE ADJUSTABLE CABLE FITTING. CONTINUE TO RAISE FIXTURE- FEEDING CABLE THROUGH THE ADJUSTABLE CABLE FITTING UNTIL DESIRED MOUNTING HEIGHT IS ATTAINED. FIXTURE WILL AUTOMATICALLY BE RETAINED AT THE LAST POINT OF ADJUSTMENT. TIGHTEN LOCKING CAP ONTO RETAINER STEM.

**NOTE:** IF IT BECOMES NECESSARY TO LOWER FIXTURE, LOOSEN LOCKING CAP, DEPRESS RETAINER STEM AND LOWER FIXTURE TO DESIRED POSITION. RE-TIGHTEN LOCKING CAP.

**CAUTION:** BE CERTAIN TO SUPPORT FIXTURE INDEPENDENTLY OF CABLES WHEN DEPRESSING RETAINER STEM.

### STEP 5:

INSTALL SAFETY STOP AND CUT EXCESS CABLE AS REQUIRED.

### STEP 6:

LEVEL FIXTURE BY SLIDING SLING CABLE THROUGH THE ADJUSTABLE FITTING IN REQUIRED DIRECTION. ONCE FIXTURE IS LEVEL TIGHTEN SET SCREW ON BOTTOM OF ADJUSTABLE CABLE FITTING.



# AFC19000 SERIES FEED CABLE ASSEMBLY SAFETY AND INSTALLATION INSTRUCTIONS

## **CAUTION:**

- \* BE CERTAIN THAT POWER TO FIELD WIRING HAS BEEN TURNED OFF PRIOR TO INSTALLATION.
- \* CONNECTIONS TO FIELD WIRES AND GROUNDING OF FIXTURES MUST BE DONE IN ACCORDANCE WITH APPLICABLE LOCAL & NATIONAL CODES. INSTALLATION MUST BE PERFORMED BY QUALIFIED PERSONNEL.
- \* IT IS INSTALLERS RESPONSIBILITY TO ENSURE THAT WALL, CEILING OR JUNCTION BOX IS STRUCTURALLY CAPABLE OF SUPPORTING WEIGHT OF FIXTURE .
- \* BE CERTAIN THAT SUPPLY VOLTAGE IS THE SAME AS THAT MARKED ON BALLASTS AND TRANSFORMERS.

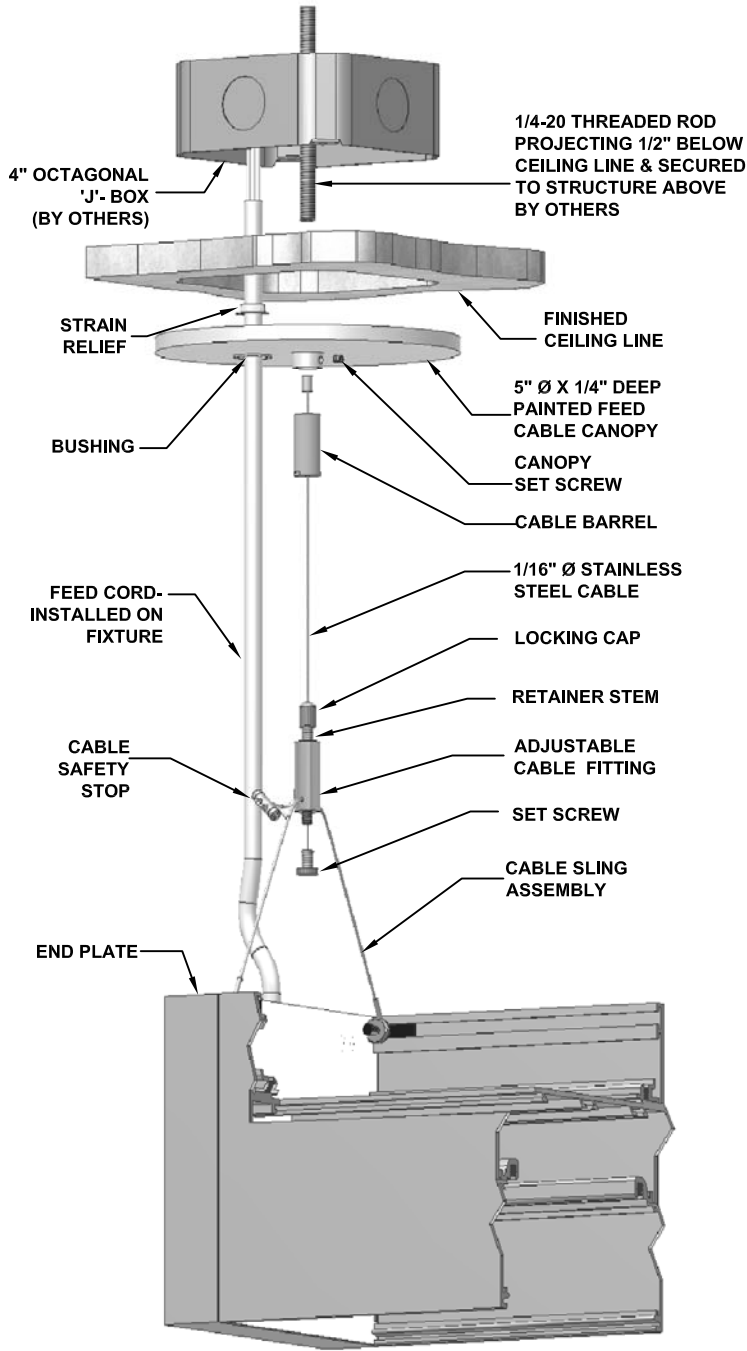

**FIG. 2**

### **STEP 1:**

DETERMINE CABLE MOUNTING SPACING (FROM FACTORY SHOP DRAWING) AND LOCATE A 4" OCTAGONAL 'J' BOX AT INDICATED INCOMING WIRE FEED POINT LOCATION(S). BOTTOM OF "J"-BOX SHOULD BE FLUSH WITH FINISHED CEILING LINE.

### **STEP 2:**

DRILL A 5/16" DIAMETER HOLE IN THE ROOF OF THE JUNCTION BOX. POSITION AND SECURE A 1/4-20 THREADED ROD (BY OTHERS) TO STRUCTURAL SUPPORT ABOVE SO THAT IT PASSES THROUGH THE HOLE DRILLED IN THE 'J' BOX AND EXTENDS 1/2" BELOW THE FINISHED CEILING LINE AS ILLUSTRATED. (FIG. 2)

### **STEP 3:**

INSTALL CABLE ASSEMBLY BY THREADING CABLE BARREL SECURELY ONTO 1/4-20 THREADED ROD AS ILLUSTRATED.

### **STEP 4:**

SECURE CABLE SLING TO FIXTURE FOLLOWING STEP 3 ON REVERSE PAGE.

### **STEP 5:**

ROUTE FEED CORD FROM FIXTURE THROUGH THE GROMMETED HOLE IN CANOPY. RAISE FIXTURE TO CABLE, ROUTING CABLE THROUGH THE CENTER HOLE IN THE CANOPY AND INTO THE CENTER OF THE ADJUSTABLE CABLE FITTING ON FIXTURE AS ILLUSTRATED. CONTINUE TO RAISE FIXTURE, FEEDING CABLE THROUGH THE ADJUSTABLE FITTING UNTIL DESIRED MOUNTING HEIGHT IS ATTAINED. FIXTURE WILL AUTOMATICALLY BE RETAINED AT THE LAST POINT OF ADJUSTMENT. TIGHTEN LOCKING CAP ONTO RETAINER STEM OF ADJUSTABLE FITTING.

**NOTE:** IF IT BECOMES NECESSARY TO LOWER FIXTURE, LOOSEN LOCKING CAP, DEPRESS RETAINER STEM AND LOWER FIXTURE TO DESIRED POSITION. RE-TIGHTEN LOCKING CAP.

**CAUTION:** BE CERTAIN TO SUPPORT FIXTURE INDEPENDENTLY OF CABLES WHEN DEPRESSING RETAINER STEM.

### **STEP 6:**

CONNECT FEED CORD TO INCOMING POWER FEED WIRES WITHIN JUNCTION BOX WITH APPROPRIATE CONNECTORS AND INSTALL STRAIN RELIEF AS ILLUSTRATED. RAISE CANOPY TO CEILING AND SECURE IN POSITION BY TIGHTENING CANOPY SET SCREW AGAINST CABLE BARREL.

### **STEP 7:**

INSTALL SAFETY STOP AND CUT EXCESS CABLE AS REQUIRED.

### **STEP 8:**

INSTALL LAMPS, ENERGIZE FIXTURE AND CHECK FOR PROPER OPERATION.

